

*Acoustic
Image*[®]

**Musical Amplification:
Setting The Standard**

*Owner's
Manual*



**Combo
Amplifiers**

Contents

Welcome	
The Basics	1
Operation	2
Power	2
Preamp	2
Inputs	2
Controls	3
Notch/Low Cut Filter	3
Control Panel Drawings	4
Signal Flow Diagram	4
Effects Loop	6
Direct Out	6
Mute Switch	6
Stereo Operation	7
Effects	7
External Speaker Jack	7
Speaker Placement	8
Tilt Mechanism	8
Tweeter Switch	8
Care	8
Warranty And Repair	8
Specifications	9

The information in this manual is subject to change without notice. No part of this manual may be reproduced by mechanical, electronic or other means in any form without prior written permission from Acoustic Image.

The Acoustic Image logo is a registered trademark of Acoustic Image LLC. Contra, Coda R and Contra EX are trademarks of Acoustic Image LLC.

Welcome to Acoustic Image!

You have purchased a state-of-the-art musical instrument amplifier system, combining purity, power and portability in a package that sets a new standard in high fidelity amplification.

Each of our designs is engineered to accurately reproduce the sound of acoustic and electric instruments, delivering flat frequency response across the entire musical spectrum; extended, tight, well-controlled bass; and complete clarity of sound reproduction.

This manual provides operating information for your Acoustic Image Contra, and Coda R combo amp or Contra EX extension speaker cabinet.

The Basics

Both of our combo amps are based on the same superb class-D 400-watt (4 ohms) power amplifier, on a compact three-way speaker system (also used in the Contra EX) and on a sophisticated, sensitive preamplifier. The features of the preamp define the specific combo model.

The power amp is a high efficiency design that requires no external heat sinks or cooling fans and is capable of driving loads as low as 2 ohms. AC power and output speaker jacks are located on the rear of the enclosure. A standard, three-prong detachable AC power cord is used to provide power to the unit, while AC voltage selection switch allows the unit to operate at 115V/60 Hz or 230V/50 Hz. Japan models operate at 100V, 50/60 Hz only. See the rear panel of your amp to verify the AC voltage capability.

The Contra combo is equipped with a one-channel preamp, the Coda R adds a second, identical channel and a six-program effects unit. The input channels of both preamp types incorporate combo jack interfaces that allow either a high impedance instrument input (to optimize the sound of piezo-type pickups) or a mic input, a three-band EQ, an effects loop with return level control, a selectable notch/low cut filter for feedback control and reduction of low frequency boominess, a direct out capability with ground lift and pre/post EQ switch, a master level control and a mute switch. The two-channel preamp of the Coda R has a switch that allows the second channel to be disconnected from the main amp and connected to a satellite power amp to create a stereo system.

All of our speaker enclosures incorporate a 10-inch downfiring woofer, a 5-inch frontfiring midrange, and a 1-inch defeatable tweeter. A built-in, spring loaded tilt mechanism allows the cabinet to be tilted back to better direct sound to your listening position. The cabinet is made of an acoustically inert, high durability, injection molded polymer material which dramatically reduces the weight of the cabinet. Each unit comes with a fitted slip cover and shoulder strap. Both padded and hard shell cases are available as accessories.

While our combos and speakers are designed to play loudly--and clearly--enough so that you can be heard in most gigging situations, they are not suited to playing at extreme volumes. Generating high SPLs may require an extension cabinet such as the Contra EX or augmentation by a larger house system.

Operation

Power

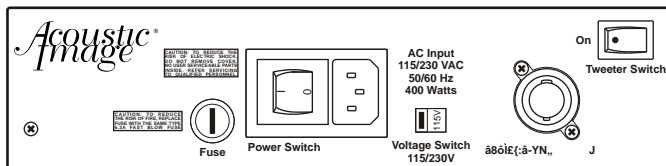

Combo Rear Panel

Plug the detachable AC power cord into the receptacle on the back of the amp and into a wall receptacle. A power switch next to the AC connector turns on power to the pre- and power amps, illuminating a “power on” indicator on the front panel of the amp. A 6.3-amp fast blow fuse is mounted on the back panel. To replace the fuse, turn off the amp, remove the AC cord and use a small screwdriver to remove the fuse from the fuse holder. A spare fuse is included with this manual.

All combos will work with either 115 volt, 60 Hz AC or 230 volt, 50 Hz AC power. A switch located on the rear panel selects the appropriate voltage. Note that the correct AC power cord must be used for connection to the appropriate wall plug. If you do not have the right cord, you can buy one from an electronics or computer store. Be sure the switch is in the correct position for the intended application. **Operation at 230 volts with the switch in the 115 volt position will damage the unit.**

Please note that units sold in Japan operate at 100 volts only. The above mentioned voltage switch is not available for these units. **Operation of a 100 volt amp at any other voltage than 100 volts will damage the unit.**

Preamp

Refer to the signal flow diagram and the control panel drawings for more information (page 4).

Inputs

The Contra and Coda R use combo jacks for the input to each channel of their preamp. Either an XLR or 1/4 inch connector can be plugged into this type of jack. The 1/4 inch input has a 1 megohm input impedance that is optimized to get the best sound from piezo pickups. The XLR input is a low impedance balanced input with sufficient gain to allow microphones to be plugged into it. Phantom power is available through the connector for powering a mic or outboard preamp and can be activated using the push button switch located next to the connector. To avoid an audible “pop”, set the mic input level control all the way off when switching on the phantom power. An LED indicates when phantom power is on. The two channels of the Coda R combo can be blended to mix two instruments, 2 microphones or a mic and an instrument thereby performing much like a small PA system.

Controls

The preamp has the following controls in each channel: input level, bass, mid, treble and effects level. In addition, there is a variable frequency, selectable notch/low cut filter in each channel and a master level control that affects both channels.

Level

The input level controls the level of the signal at the input stage of the preamp. The master volume controls the level of the signal at the output of the preamp (at the input of the power amp). Set the master control at "12 o'clock" and the input level at zero. The input level should then be used to control the overall output of the unit. The two controls are provided to allow independent control of "house" volume and "stage" volume when the unit is used as a stage monitor with a connection to a house PA. See the discussion under "Direct Out" below.

The maximum volume at which the system will play is limited by the capability of the speaker system. A 10-inch driver in a small cabinet has a limitation in how loudly it will play. If more volume is needed, use a Contra EX extension cabinet or take a feed from the Direct Out jack to a PA system or another amplifier.

Tone

Each tone control has a center detent at the flat position. Experiment with settings to achieve the frequency balance that sounds best to you. In general, small values of boost and cut are best. The amp is designed with flat frequency response so only minor corrections should be required to compensate for room effects or "peaky" pickups in order to maintain the balanced response desired for acoustic instrument amplification. To minimize electronic noise, avoid operating all controls simultaneously at their maximum settings.

The bass control is a shelving-type that affects frequencies below 250 Hz and with a maximum boost/cut of 15 dB. The mid control affects frequencies between 300 Hz and 2000 Hz and has a maximum boost/cut of 15 dB. The treble control is also a shelving-type that affects frequencies above 1000 Hz with a maximum boost/cut of 25 dB.

Notch/Low Cut Filter

The notch/low cut filter is a fixed amplitude, variable frequency type that inserts either an 18 dB cut or a 12 dB per octave rolloff at frequencies between 30 and 800 Hz, depending on the position of the control. Approximate frequency settings are noted on the frequency control. Note that the first half of the control's rotation affects frequencies from 30 to 70 Hz, the last half of the rotation affects frequencies between 70 and 800 Hz. This is done so that there is plenty of control in the critical low frequency range. The notch filter is used to

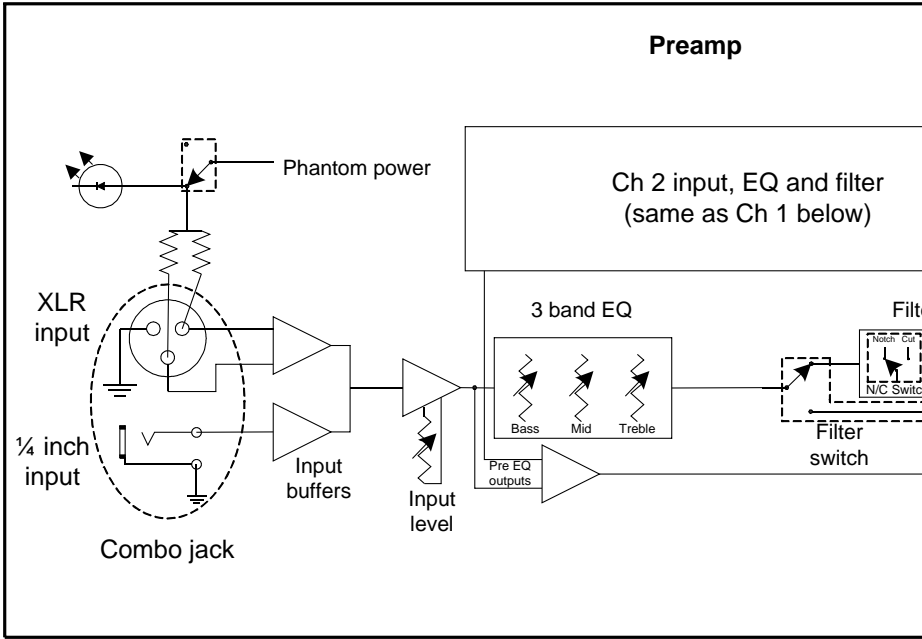

Signal Flow Diagram

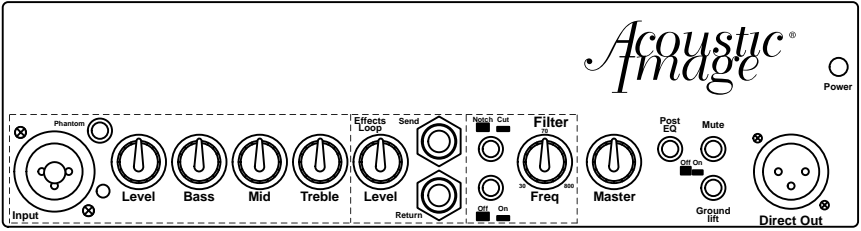

Contra Control Panel

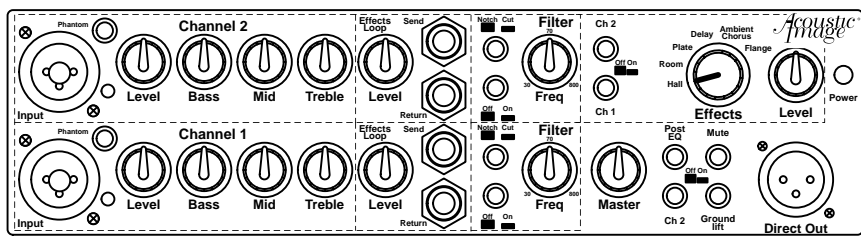
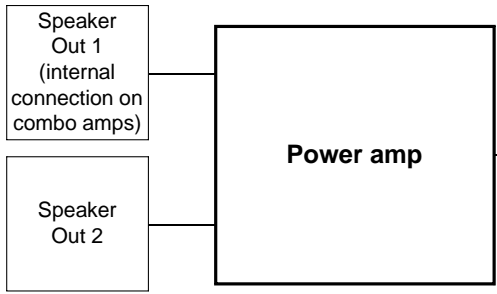
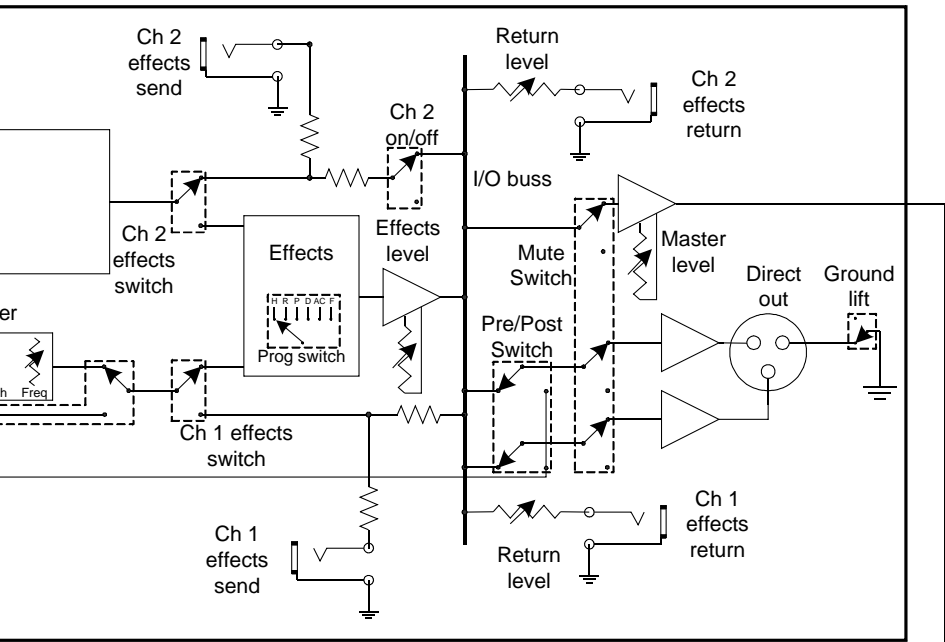

Coda R Control Panel

remove a given feedback frequency to reduce feedback “howl”. The low cut filter is used to reduce the bass output in cases where room location or instrument/pickup combination results in “boomy” sound. To use either, push the on/off switch to turn on the filter circuit then select the filter type using the notch/cut switch. Start with the control fully counterclockwise and gradually turn it clockwise until the desired effect is achieved. Experiment with the position of the control to give you the sound you like best.

Effects Loop

Acoustic Image preamps have output (“Send”) and input (“Return”) capability in each channel to allow you to use effects boxes. The send output is affected by the input volume and tone controls and can also be used as a preamp output for driving other power amplifiers. The Return input can be used to directly connect an external preamp to the unit’s power amp. The effects level control in each channel controls the volume of the returned (“wet”) signal relative to the original (“dry”) signal. Because the effects loop is a parallel type, plugging something into the send output does not interrupt the signal path. So, a tuner can be plugged into the send output without affecting the signal going through the amp. When the effects loops are not used, the level controls should be set at zero.

The return input can also be used as an auxiliary input for connecting other line level signals such as a CD player.

Direct Out

An XLR jack is provided for a Direct Out connection that allows the system’s output to be fed to mixing boards of house PA systems or recording studios. As a result, the instrument amplified by the unit can be recorded or further amplified by the house PA system. In the Coda R combos, the Direct Out signal is the combined output of the two channels. A switch is provided to allow you to select whether the output from the Direct Out jack is affected by the tone controls (post EQ) or not (pre EQ).

The input level control affects the level of the Direct Out signal, the master level does not. This allows independent adjustment of the “stage” volume (the volume coming from the combo amp) and the “house” volume (the volume in the house PA system) when the unit is used as a stage monitor. Once the level has been set for the house, if more volume is needed on stage, the master level can be increased. This will increase the stage volume but not the volume in the house PA.

A ground lift switch is available to “lift” the ground from the output of the direct out--reducing noise should a ground loop create hum when the unit is connected to a mixing board.

Mute Switch

A switch is provided to allow you to mute the output of the amplifier without having to turn the amp off. This will allow you to tune your instrument on stage without being heard. The amp output and direct out signals are both muted by the switch.

Stereo Operation

The two-channel preamp of the Coda R can be operated in stereo mode. When it is in the “on” position, the switch labeled “Ch 2” connects the channel to the internal power amp and speaker. When it is in the “off” position, it is disconnected from the internal amp but is accessible from the channel 2 send output. By connecting the send output to a satellite power amplifier (such as our Focus SA), and putting the switch in the off position, the preamp operates in stereo mode. Note that channel 2 remains in the direct out signal even when the switch is in the off position. This is done since stereo operation is typically a “stage” mode but not a “house” mode (house systems are typically not stereo). **Note that channel 2 will not be heard through the Coda R’s speaker system unless the Ch 2 switch is in the depressed or on position. If you are not hearing channel 2 in the output, check to be sure that the switch is on.**

Effects (Coda R only)

Our high-quality effects units (which use the Alesis DSP chips) offer 6 program selections: 3 reverb programs (Hall, Room and Plate), a delay, an ambient chorus and a flanger. There are switches to select which of the two channels are processed by the effects unit. Either channel can be connected to the effects unit. If both switches are engaged, the selected program appears in both channels. A level control affects the level of the reverb signal that is mixed with the “dry” signal to control the overall effect of the selected program. You should experiment with both the program selection and the level control to find the sound that you prefer. When effects are not used, the switches for both channels should be off and the level control should be turned fully counterclockwise.

External Speaker Jack

An extension speaker (ideally, the Contra EX) can be connected to the amp to increase its output level, using the jack provided on your amp’s rear panel. Speakers are connected via Neutrik Speakon connectors (“twist lock” type). These connectors are used because of their low contact resistance and non-shorting operation. The output of each Speakon connector is wired to pole “1”. Make sure the cables you use to connect an external speaker are similarly wired. Cables with Speakon connectors are available from Acoustic Image if you are unable obtain them from your local music store.

The power amplifier is capable of driving speaker loads as low as 2 ohms. Use a high quality speaker system in order to get the maximum performance from the amp. The Acoustic Image Contra EX is an excellent choice.

The power amp is short circuit protected. If a short is connected to the extension speaker jack (or if the internal speaker is shorted), the output signal will be interrupted until the short is removed. If a short is present, you will hear a ticking sound at 3 to 4 second intervals which indicates that the short circuit

protection is working. **To be on the safe side, you should shut off the power to the amp before connecting or disconnecting speakers from the unit.**

Speaker Placement (Combos or Contra EX)

The omnidirectional low frequency output of the Contra, Coda R or Contra EX makes speaker placement relatively noncritical. You will easily be heard all over the bandstand no matter where one or more are located. However, best results are obtained when the cabinet is placed on the floor. Putting the unit on a shelf or stand will reduce bass frequencies. There may be circumstances where this is desirable. Again, feel free to experiment to find the sound that is best for you.

Tilt Mechanism

In some settings, such as a hollow stage or small, “boomy” room, your amp or enclosure will produce too much bass. One way to cut unwanted bass output is to use the built in tilt back feature to lift the front of the cabinet, reducing the coupling to the floor. To do this, pull the stand into its forward position and set the combo in place on the floor. The stand is spring loaded so when you pick up the unit, the stand will spring back into its storage position. You may want to use the tilt stand at all times in order to aim the high frequency output of the speaker toward your ear so that you can better hear the amp.

Tweeter Switch

An on-off switch for the tweeter is mounted on the back panel of the combo unit. Try the unit with the tweeter on and off to decide which sounds best to you. Since the tweeter covers only the last octave of the musical spectrum, you will find its effect to be subtle, particularly with bass instruments.

Care

Acoustic Image combos and cabinets are made from injection molded polymer materials. A little care will keep yours looking new for years to come. Use a clean, dry cloth to clean the cabinet and metal parts of the amplifier.

Warranty and Repair

We stand behind our products with a full warranty of five years from the date of purchase. Should a problem arise, please call us before returning your amplifier or enclosure. Naturally, our warranty does not cover products that have been damaged through misuse. Be sure to check our web site regularly, we have an FAQ section and we post helpful information for getting the most out of your Acoustic Image product.

Warranty Information

Serial Number _____

Acoustic Image
7517 Precision Dr, Suite 102
Raleigh, NC 27617

Phone: 919-598-3113
Fax: 919-957-3294
www.acousticimg.com

Specifications

System (all models)

Frequency Response	30 Hz - 20 kHz, (40 - 16 kHz \pm 3 dB)
Max SPL	>112 dB at 1 meter
AC Power	115V/60 Hz or 230V/50 Hz, switchable, Japan version is 100V, 50/60 Hz only
Size	12" H x 15" W x 13" D
Weight	19 lbs, 16 lbs (EX)

Preamp (Mic and Instrument Inputs through combo jack)

Mic Input	600 ohm balanced, XLR connector
Phantom Power	38 volts, on/off switch w/LED indicator
Instrument Input	1 M Ω impedance, 1/4 inch jack
Direct Out	+4 dB, balanced, XLR connector, ground lift, pre/post EQ selector
Effects Loop	Parallel type with return level control
Bass Control	Shelving type, \pm 15 dB at 60 Hz
Mid Control	\pm 15 dB at 650 Hz
Treble Control	Shelving type, \pm 25 dB at 10 kHz
Notch Filter	>-18 dB sweepable from 30 to 800 Hz
Low Cut Filter	-12 dB/octave sweepable from 30 to 800 Hz

Effects (Coda R only)

Type	Digital with 6 presets and level control
Program Presets	3 reverb (hall, room, plate), delay, ambient chorus, flange

Power Amp (all models)

Topology	Class D (PWM)
Switching Frequency	200 kHz
Output Power	>400 W, >500 W with 4 ext. cab.
External Speaker Output	Neutrik Speakon type (pole 1), 4 min.

Speaker System (all models)

Woofer	10 inch, downfiring
Midrange	5 inch, forward firing
Tweeter	1 inch forward firing with on/off switch
Crossover	Passive, alignment corrected
Impedance	4
Power rating	300W

Supplied Accessories

Fitted slip cover with cord storage pocket and shoulder strap

Available Accessories

Padded gig bag with shoulder strap made by Mooradian, hard shell case, "twist lock" to "twist lock" and "twist lock" to 1/4 inch speaker cables.

CONTRA™
SERIES III
Model 510 BA

CODA R™
SERIES III
Model 511 AA

CONTRA EX™
SERIES III
Model 510 EX

Acoustic
Image® *Musical Amplification:*
Setting The Standard